



**Conveyors & Automated
Handling Solutions**

Lineshaft Powered Roller Conveyors



MONK Conveyors Limited

Unit 9, The Christy Estate, Ivy Road, Aldershot, Hampshire GU12 4TX
Tel: +44(0)1252 369800 Fax: +44(0)1252 369801 Email: sales@monk-conveyors.co.uk
www.monk-conveyors.com

Overview - Lineshaft Powered Roller Conveyors

The most versatile and economical conveyor available in material handling. For complex configurations of conveyors fewer drives are required compared to conventional equipment. Another unique advantage of Lineshaft Conveyor is the number of ancillary modules which can be driven from one motor by means of couplings and universal joints. They can be easily reconfigured to meet current and future demands. Available in powder coated steel as standard also available in aluminium and stainless steel.

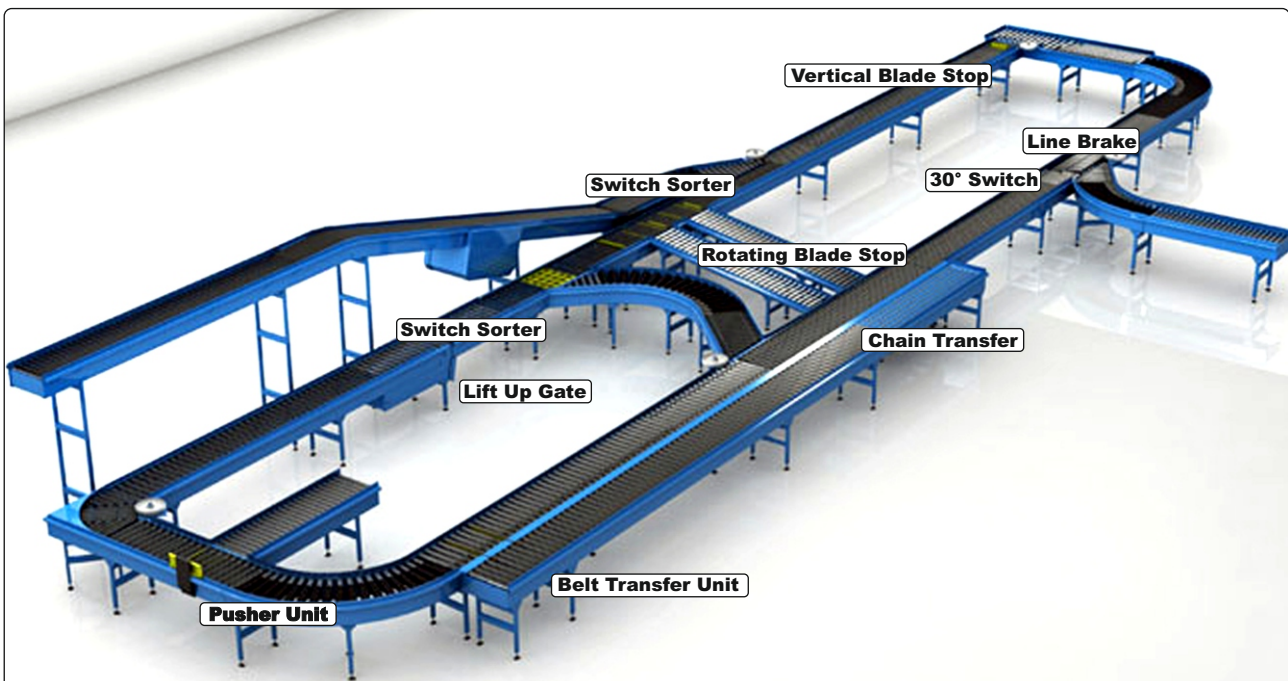

Benefits

- A proven modular design, highly configurable, simple to install and maintain.
- Versatility / adaptability in product handling.
- Allows for a variety of arrangements to be made from standard components.
- Reduced power consumption.
- Reliable noncontact accumulation thus eliminating product damage.
- Easily re-configurable if further ancillary items are added.
- Increased driving capacity.
- Reduced noise.



Lineshaft Conveyor (Light Duty) XU30

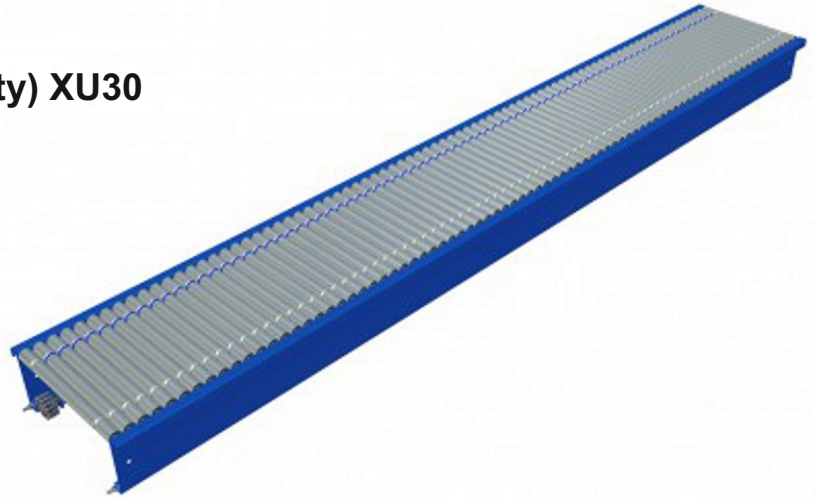

- **35mm** diameter rollers, set at **37.5mm** pitch.
- Drive capacity per roller 4Kg.
- 178mm x 32mm x 2.5mm fully jig welded 'Z' section framework.
- Standard speeds available 12, 15, 20, 25 and 30 metres per minute as nominal (other speeds available).
- Suitable for low pressure accumulation.
- Suitable for conveying very small products with a minimum product length of 113mm.
- Drive up to 36 metres from one 0.37Kw drive unit.
- Supplied in 3 metre fully assembled lengths as standard. Other lengths available on request.
- Standard widths available: 412, 462, 512, 612, and 762mm. Other widths available upon request.
- Full product testing available.
- Also available in stainless steel and aluminium.

Lineshaft Conveyor (Light Duty) XU30S

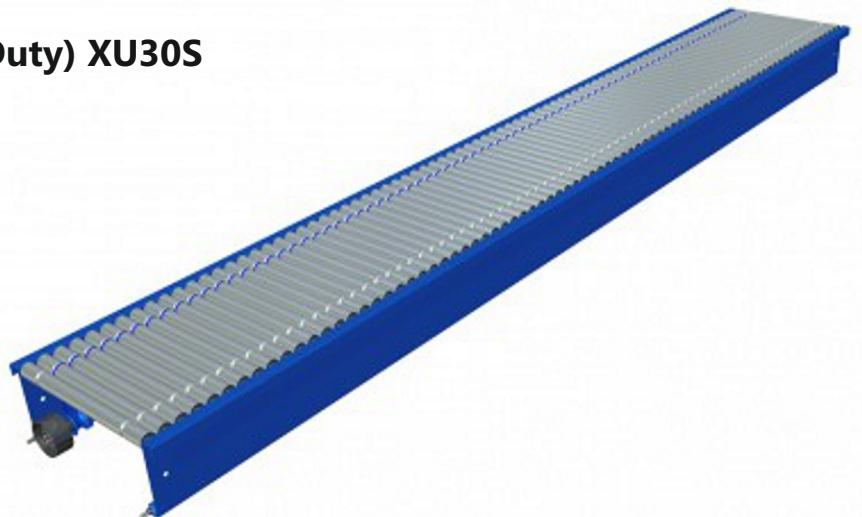

- **25.4 mm** diameter rollers fitted with **35mm** diameter plastic sleeves with rollers set at **37.5mm** pitch.
- Drive capacity per roller 4Kg .
- 178mm x 32mm x 2.5mm fully jig welded 'Z' section framework.
- Standard speeds available 12, 15, 20, 25 and 30 metres per minute as nominal (other speeds available).
- Suitable for low pressure accumulation.
- Suitable for conveying very small products with a minimum product length of 113mm.
- Drive up to 36 metres from one 0.37Kw drive unit.
- Supplied in 3 metre fully assembled lengths as standard. Other lengths available on request.
- Standard widths available: 412, 462, 512, 612 and 762mm. Other widths available on request.
- Full product testing available.
- Also available in stainless steel and aluminium.



Lineshaft Conveyor XU60/90-75mm Pitch

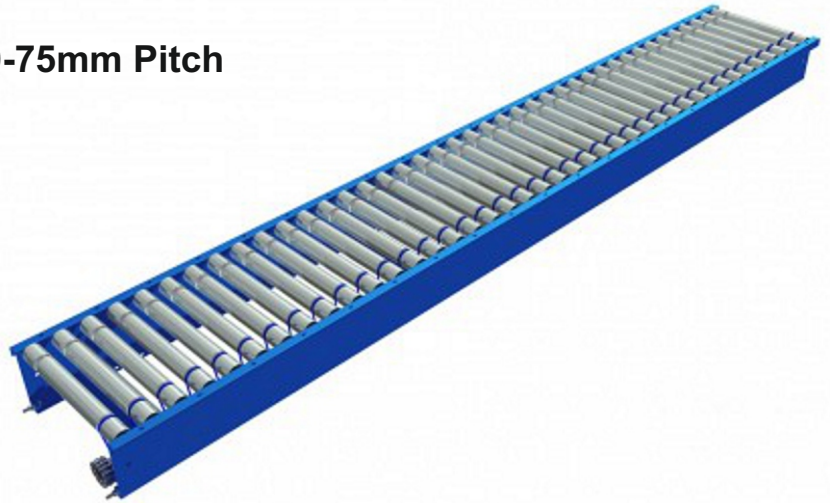

- **50mm** diameter rollers.
- Drive capacity - XU60 8kg and XU90 12kg per roller.
- Suitable for low pressure accumulation.
- Drive up to 36 metres from one 0.37Kw drive unit.
- Suitable for conveying very small products with a minimum product length of 225mm.
- Supplied in 3 metre fully assembled lengths as standard. Other lengths available on request.
- Standard widths available: 412, 462, 512, 612, 762 and 912mm. Other widths available upon request.
- Full product testing available.
- Also available in stainless steel and aluminium.

Lineshaft Conveyor XU60/90-100mm Pitch

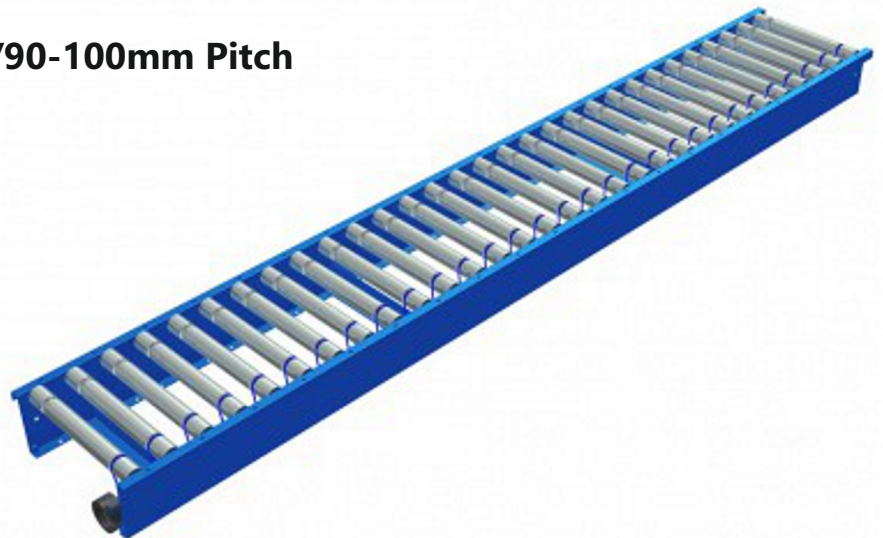

- **50mm** diameter rollers.
- Drive capacity - XU60 8kg and XU90 12kg per roller.
- Suitable for low pressure accumulation.
- Drive up to 48 metres from one 0.37Kw drive unit.
- Suitable for conveying very small products with a minimum product length of 300mm.
- Supplied in 3 metre fully assembled lengths as standard. Other lengths available on request.
- Standard widths available: 412, 462, 512, 612, 762 and 912mm. Other widths available upon request.
- Full product testing available.
- Also available in stainless steel and aluminium.



Lineshaft Conveyor XU60/90-150mm Pitch

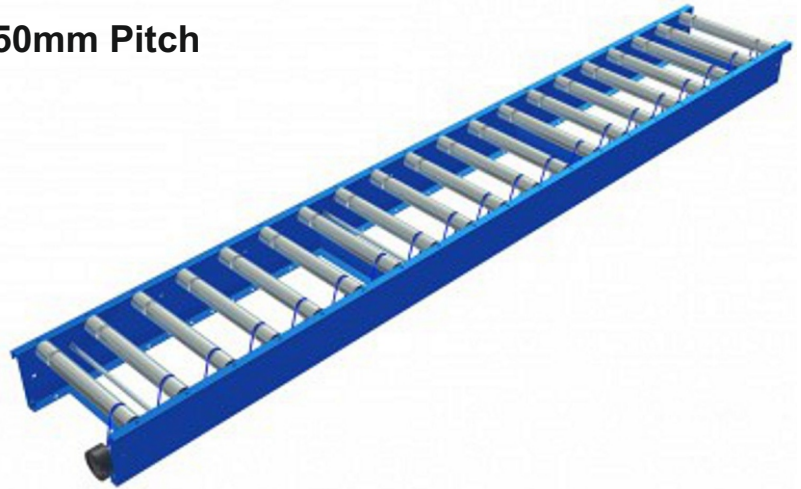

- **50mm** diameter rollers.
- Drive capacity - XU60 8kg and XU90 12kg per roller.
- Suitable for low pressure accumulation.
- Drive up to 72 metres from one 0.37Kw drive unit.
- Suitable for conveying very small products with a minimum product length of 450mm.
- Supplied in 3 metre fully assembled lengths as standard. Other lengths available on request.
- Standard widths available: 412, 462, 512, 612, 762 and 912mm. Other widths available upon request.
- Full product testing available.
- Also available in stainless steel and aluminium.

Bend Unit For XU30, XU30S, XU60 and XU90.



- All bends have true taper plastic sleeved rollers to ensure correct load orientation.
- 75mm pitch on inner rail.
- 50mm diameter zinc plated rollers are double grooved at the drive belt positions.
- Heavy duty XU90 belts are used throughout.
- Bend units can be supplied fitted with geared motor units, (60° and 90° only).
- For smaller products intermediate rollers are available & supplied loose for on site fitting.
- The lineshafts are inter-connected by constant velocity (needle roller bearings) universal joints, housed within a rubber gaiter.
- All bends have an inside radius of 859mm.
- Angles available 30°, 45°, 60° and 90°.
- Accumulation not advised.
- Standard widths available: 412mm, 462mm, 512mm, 612mm, 762mm and 912mm. Other widths available on request.



Corner Turn Unit



- Suitable for use with 412 and 462mm inside track widths
- Two types available: XU30 - 612mm² fitted with 35mm diameter rollers and XU60 - 612mm² fitted with 50mm diameter rollers.
- Used where space is restricted. They are only a substitute for bends and have limitations with respect to maintaining correct product orientation. This is determined by the product length to width dimension ratio.
- Supplied with an adjustable inner nylon turning wheel fitted to assist packages through the corner turn.
- Supplied with an outer guide rail.
- Accumulation not advised.

Lineshaft

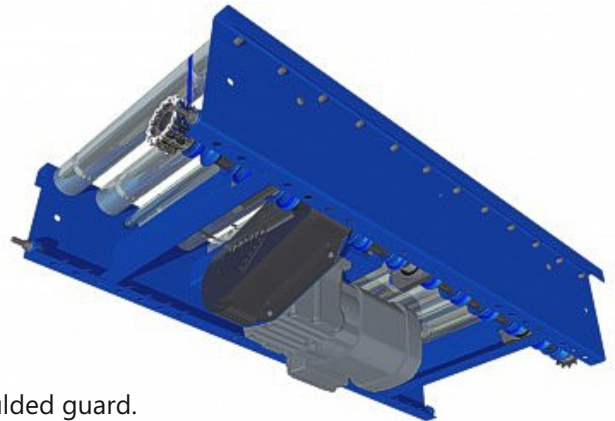

- Available for XU30, XU30S, XU60 and Xu90.
- Can be fitted to straight track as well as 90° and 60° bends.
- Urethane mounted to reduce transmission noise.
- Screwed tensioner to ensure correct timing belt tensioning.
- Moving parts are fully enclosed in a removable vacuum moulded guard.
- SEW Eurodrive geared motor units - 0.37 and 0.75 kW available
- Standard speeds available 12, 15, 20, 25 and 30 metres per minute.

Total length of straight track driven from 1 drive unit - to be approx. equal either side of drive unit			
Roller Centres on Straight Track	Conveyor Speed		
	10 m.p.m	20 m.p.m	30 m.p.m
37.5 & 75mm	36m	18m	12m
100mm	48m	24m	16m
150mm	72m	36m	24m

Total length of straight track driven from 1 drive unit - to be approx. equal either side of drive unit						
Roller Centres on Straight Track	90° Bend	60° Bend	45° Bend	30° Bend	Switch & Merge	Twin Chain Transfer
37.5 & 75mm	4.90	3.70	2.40	1.90	7.60	1.00
100mm	6.10	4.70	3.20	2.40	10.20	1.25
150mm	9.20	7.00	4.80	3.50	15.20	2.00



Chain Jump Unit for XU30, XU30S, XU60 and XU90.



- A jump chain assembly comprises two sprockets and a chain which are used for transferring the drive between lineshafts when they are positioned on opposite sides of the conveyor.
- Standard jump chain 1:1 ration, 17 tooth 1/2" pitch sprockets.
- Speed up jump chain ratio 2:1 available for product separation (14 tooth: 19 tooth 1/2" pitch sprockets and with speed up spools).
- Adjacent jump chain available for driving two conveyors which are side by side 1:1 ration 17 tooth 1/2" pitch sprockets.

Lineshaft Lift Up Gate for XU60 & XU90



- Fitted with plastic rollers slave driven from a 24V motorised roller.
- Fixed section of track must be 75mm roller pitch.
- 900mm clear access given when gate is in the 'up' position.
- To be used for emergency access only.
- The lifting process is by manual operation, although the design does incorporate a spring assisted mechanism which controls and cushions the raising and lowering operation.
- Drive cannot be taken through to the next section of conveyor and the gate assembly cannot be fitted to a bend.
- Can be positioned back to back to give a 'TowerBridge' arrangement.
- Standard widths available: 412mm, 462mm, 512mm, 612mm, 762mm and 912mm. Other widths available on request.



Mobile Conveyor for XU30, XU30S, XU60 and XU90.



- Braked swivel castors as standard.
- Variable heights and lengths available.
- Can be used should site conditions require sections of conveyor to be moved to allow for the passage of fork lift trucks or other equipment through the line of conveyor.
- Standard widths available: 412mm, 462mm, 512mm, 612mm, 762mm and 912mm. Other widths available upon request.

Lineshaft Incline / Decline Unit for XU60 & XU90



- Incline section uses XU90 conveyor with rollers at 75mm pitch.
- The maximum angle of incline/decline which is recommended with the standard specification of conveyor equipment is 5° depending on the product length and weight, this may be increased.
- We recommend the fitting of intermediate rollers at both ends of the intersection for a distance equal to the maximum product length to prohibit 'nosing-in' between the rollers.
- We recommended that product trials are carried out at our works.



30° Merge unit for XU30, XU30S, XU60 and XU90.



- Right and left hand merges available.
- The rollers are always fitted at 75mm pitch and driven with heavy duty drive belts.
- The ability to merge tracks at 90° and parallel lines when using 60° and 30° bends.
- Merge unit includes jump chains and universal joints allowing the drive to be continued through the unit.
- Can be used in conjunction with XU30 and XU30S conveyor, but intermediate rollers must be fitted.
- Supplied with a turning wheel for positioning at the leg intersection to assist with guidance of the product.
- Accumulation is not advised.
- Maximum throughput of 25 packs per minute based on conveyor speed of 50 metres per minute.
- Standard widths available: 412mm, 462mm, 512mm, 612mm and 762mm. Other widths available on request.

Lineshaft 90° Junction for XU60 & XU90.



- This junction is only used when space is at a premium and the need to merge at 90° to the main line.
- An adjustable nylon guide wheel is fitted to assist in the turning of the product.
- Includes jump chains which allows the drive to be continued through the unit.
- We recommended that product trials are carried out at our works



Vertical Blade Stop for XU30, XU30S, XU60 and XU90.

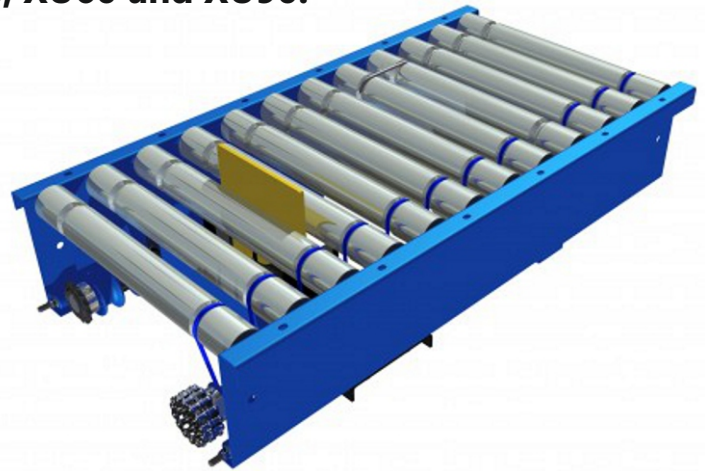

- Incorporates double acting pneumatic air cylinder.
- Air consumption for each cylinder operation 0.70 litres.
- This stop can be incorporated into straight track positioned in between roller pitches for XU60/XU90 and would replace a roller for XU30/XU30S.
- Speed up spools are supplied at the stop position to increase gaps between loads. Speed up jump chain assemblies can also be used for this application.
- Standard widths available: 412mm, 462mm, 512mm, 612mm, 762mm and 912mm. Other widths available on request.

Rotating Blade Stop for XU60 & XU90

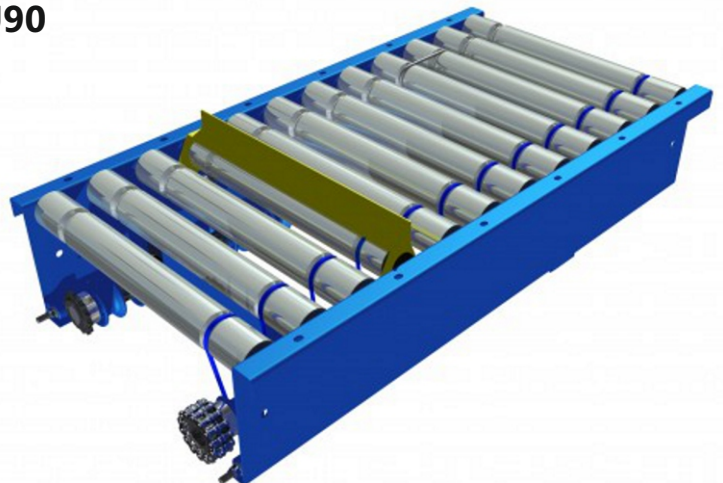

- XU90 fitted with twin cylinders as standard.
- Total air consumption for each operation per cylinder - 0.24 litres
- This stop unit has a full width blade and is designed to fit into any straight track position.
- Maximum product weight 15Kg.
- Standard widths available: XU60 - 412mm, 462mm and 512mm, XU90 - 412mm, 462mm, 512mm, 612mm and 762mm.
- Speed up spools are supplied at the stop position to increase gaps between loads.
- Speed up jump chain assemblies can also be used for this application.
- This type of stop is particularly useful where conveyor height is to be of a minimum and in two tier systems.
- Incorporates single acting spring return pneumatic air cylinders.
- XU60 upto and including 512mm are fitted with single cylinders, 612mm and 762mm are fitted with twin cylinders.

Line Brake for XU30, XU60 & XU90



- A pneumatically operated rubber covered friction pad comes into contact with the underside of the rollers and gives negative line pressure over a standard brake length of 890mm.
- It can be used in conjunction with stops to reduce line pressure and provide singulation of products to chain transfer units, packing and wrapping machines etc.
- Incorporates two single acting, spring return pneumatic cylinders.
- Total air consumption per operation 0.10 litres.
- For accumulation control, see our 'Technical Manual.'

Switch Sorter for XU60 & XU90.



- Available at 45° switching angle.
- Incorporates double acting pneumatic cylinders.
- Can be supplied right handed, left handed or bi-directional.
- Minimum product size 200mm x 200mm the sorter wheels are independently driven from a 0.37 kW SEW motor, to give either 60 or 110 metres per minute.
- We recommend that an inverter is fitted to the gearbox to enable fine tuning of the speed that will be required to suit your application.
- Normally used in conjunction with a 45° mitre section, although other options are available.
- Accumulation is not advisable on these units.
- Maximum operations 3000 products per hour.
- Standard widths available: 462mm, 612mm, 762mm and 912mm.



30° Mitre Section for XU60 & XU90



- Used where one conveyor feeds into or diverts from another.
- Also available as 45°.
- Standard widths available 412mm, 462mm, 512mm, 612mm, 762mm and 912mm. Other widths available on request.

Pusher Unit for XU30, XU30S, XU60 and XU90.

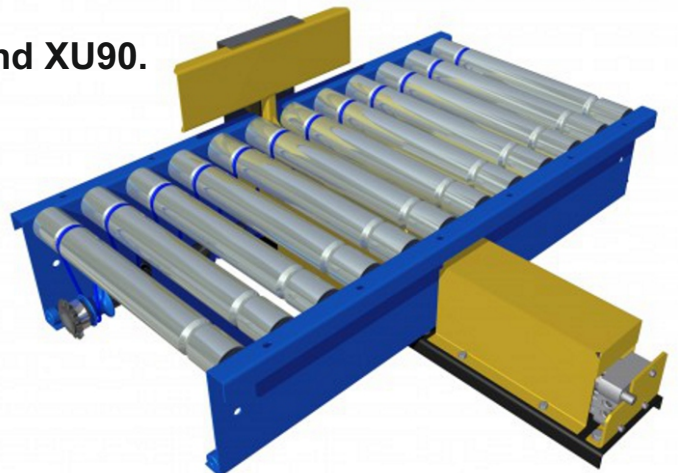

- Comprises a rodless cylinder which has an arm attached to its saddle.
- When the cylinder is energised the arm traverses across the track width and pushes products onto a conveyor at 90 °.
- Incorporates a double-acting pneumatic air cylinder, 32mm bore.
- Total air consumption for double stroke 7.76 litres per cylinder based on 700mm stroke.
- Suitable for moving a maximum load of 25kg.
- Maximum operations 20 per minute. Please contact us for off set loads and higher throughputs.



Chain Transfer Unit for XU30,XU30S,XU60 & XU90



- The minimum chain centres are 112.5mm for XU30 and 150mm for XU60 and XU90.
- Maximum of 15 operations per minute.
- Maximum lift twin chain 50Kgs. Maximum lift triple chain 100Kgs.
- Drive to the transfer chains is via sprockets on the main lineshaft.
- The rise and fall of chains is actuated by double acting pneumatic cylinder(s).
- Available in twin or triple chain transfers with either steel or nylon chain.
- One cylinder is required for twin chain transfers. Two cylinders are required for triple chain transfer.
- Total air consumption for double stroke 0.4 litres per cylinder.
- Standard widths available: 412mm, 462mm, 512mm, 612mm, 762mm and 912mm. Other widths available on request.

Vertical Lift Chain Transfer Unit for XU30, XU30S, XU60



- The minimum chain centres are 150mm.
- Maximum of 20 operations per minute.
- Maximum lift 50Kgs.
- Drive to the transfer chains is via sprockets on the main lineshaft.
- The rise and fall of chains is actuated by double acting pneumatic cylinder.
- Available in twin or triple chain transfers with either steel or nylon chain.
- Two cylinders are required for twin chain transfers. Four cylinders are required for triple chain transfer.
- Total air consumption per operation 0.51 litres per cylinder.
- Standard widths available: 412mm, 462mm, 512mm, 612mm, 762mm and 912mm. Other widths available on request.



Belt Transfer Unit for XU30, XU60 and XU90.



- The minimum belt centres are 150mm.
- Maximum of 25 operations per minute.
- Maximum lift 70Kgs.
- Independently driven from a geared motor unit via pulleys on a separate shaft.
- The rise and fall of chains is actuated by a double acting pneumatic cylinder(s).
- Available in twin or triple belt transfers.
- Polyurethane truly endless belt with co-extruded backing.
- Total air consumption per operation 1.04 litres per cylinder.
- Standard widths available: 412mm, 462mm, 512mm, 612mm, 762mm and 912mm. Other widths available on request.

Pack Positioning Unit for XU60 only.



- Supplied left or right hand.
- Fitted with angled driven rollers set at 60mm pitch, which guide the product to the left or right hand side of the conveyor track. This provides a fixed product position for infeed into various types of machinery and within scanning distance for barcode readers and labelling machines etc.
- Each unit includes steel wheel sideguide on one side only.
- We recommended that product trials are carried out at our works.
- Standard widths available: 462mm and 612mm. Other widths available on request.



Pack Turn Unit for XU60 only.



- Supplied left or right hand.
- The unit is fitted with driven rollers set at 75mm pitch.
- Incorporates a jump chain assembly with speed-up spools to give an increase in line speed of 2:1 ratio. This increase in speed, coupled with the hinged nudger bar turns the product through 90°, subject to its weight, length and width ratio.
- Each unit includes steel wheel sideguide on one side only.
- Maximum product weight 8Kg.
- For weights in excess of 8Kg contact sales office.
- We recommended that product trials are carried out at our works.
- Standard widths available: 462mm and 612mm. Other widths available on request.

Guard Rail and Underguarding



Guard Rail

Two types: 60mm high pressed steel angle or 150mm high pressed channel.

Supplied in 3.0 metre lengths as standard. Should odd lengths be supplied, additional holes may need to be drilled for on site fixing.

Underguarding

Lineshaft under-guarding is supplied as an optional extra, this is formed from a grey plastic material, which is positioned locally to the drive shaft but does not extend fully to cover the complete underside of the conveyor.

Complete, powder coated full width under-sheeting is available if required. Please contact our Sales Team for details.

Stop and Line Brake Applications

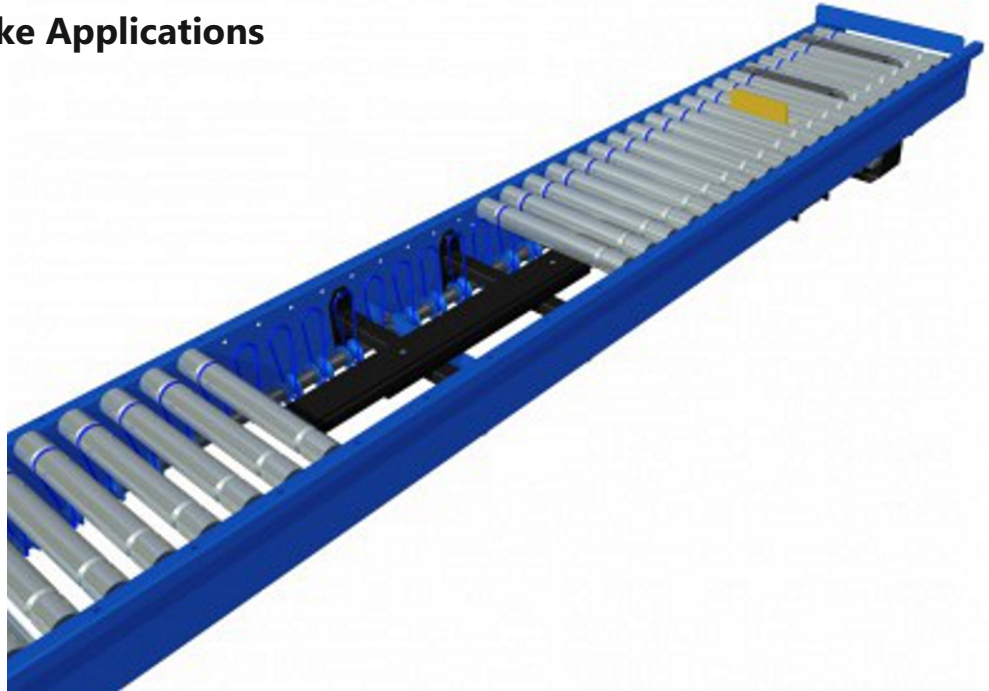

- Fast operation, capable of picking up minimum spaces between cartons.
- Small bore / stroke cylinder ensures low usage of compressed air.
- Standardised components ensure quality stops at low cost.
- Quickly manufactured to fit any track width.
- Spring return on rotating blade stop cylinder for safety.
- Both vertical and rotating stop units include the necessary larger diameter drive spools to speed up rollers and create gaps between loads.
- Easily repositioned on site if system requires change.

Fixed End Stop



- Two types are available: 60mm high pressed steel angle and 150mm high pressed steel channel.



Conveyors & Automated Handling Solutions



FlexChain Conveyors

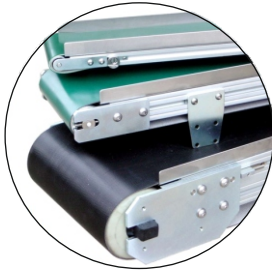

Flat Belt Conveyors



Mat Top Bend

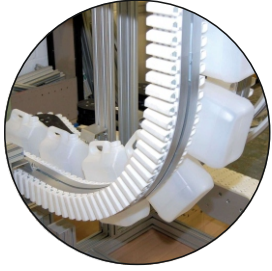

Grip Conveyors



Heavy Duty Trough Conveyors



Plastic Container Handling System

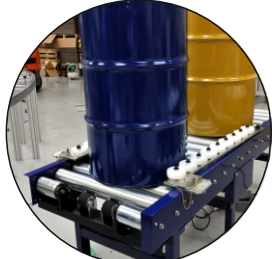

Special Roller Conveyor



Rotating Storage Tables



Diverter Units



Indexing Buffer Stores



Elevators - Plastic or Stainless Steel



Luggage Handling



Multi-Lane Flat Belts



Ready Made Meal Conveyor Line

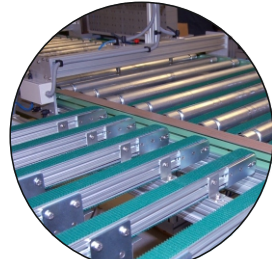

Sheet Panel Transfer Unit



Fruit Packing Line

MONK Conveyors Limited

Unit 9, The Christy Estate, Ivy Road, Aldershot, Hampshire GU12 4TX
Tel: +44(0)1252 369800 Fax: +44(0)1252 369801 Email: sales@monk-conveyors.co.uk
Visit our website at: www.monk-conveyors.com

A Private British Engineering Company

