

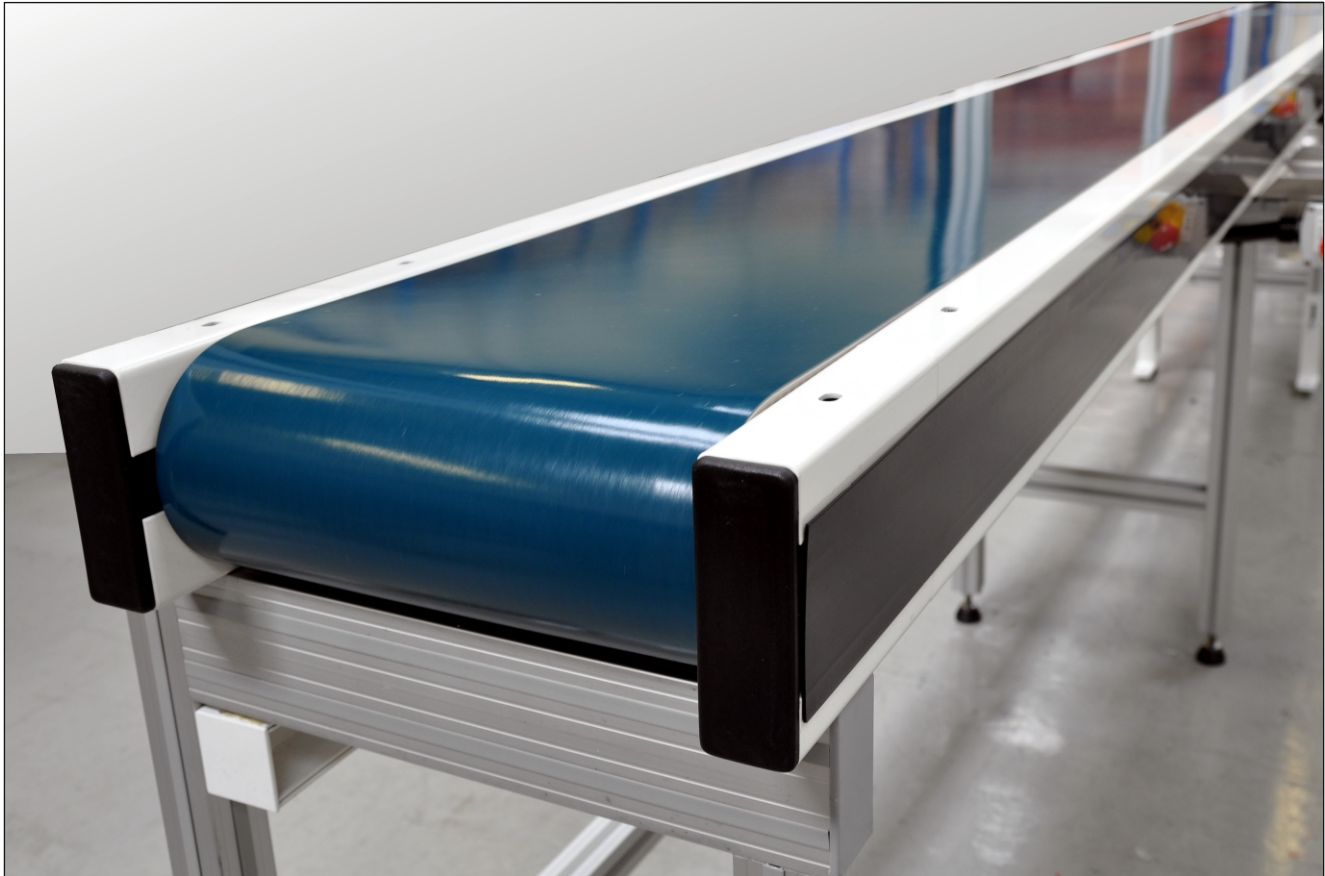

**Conveyors & Automated  
Handling Solutions**

## **Heavy Duty Belt Conveyors**



### **MONK Conveyors Limited**

Unit 9, The Christy Estate, Ivy Road, Aldershot, Hampshire GU12 4TX  
Tel: +44(0)1252 369800 Fax: +44(0)1252 369801 Email: [sales@monk-conveyors.co.uk](mailto:sales@monk-conveyors.co.uk)  
Visit our website at: [www.monk-conveyors.com](http://www.monk-conveyors.com)

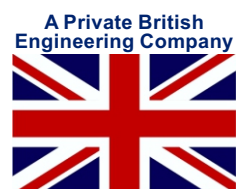



## Heavy Duty Belt Conveyors

### Overview

This robust belt conveyor is a proven product which is highly configurable and easy to install. Ideal for the handling of irregular shaped products and for changes in elevation. The modular design allows for variety of arrangements to be made from standard components.

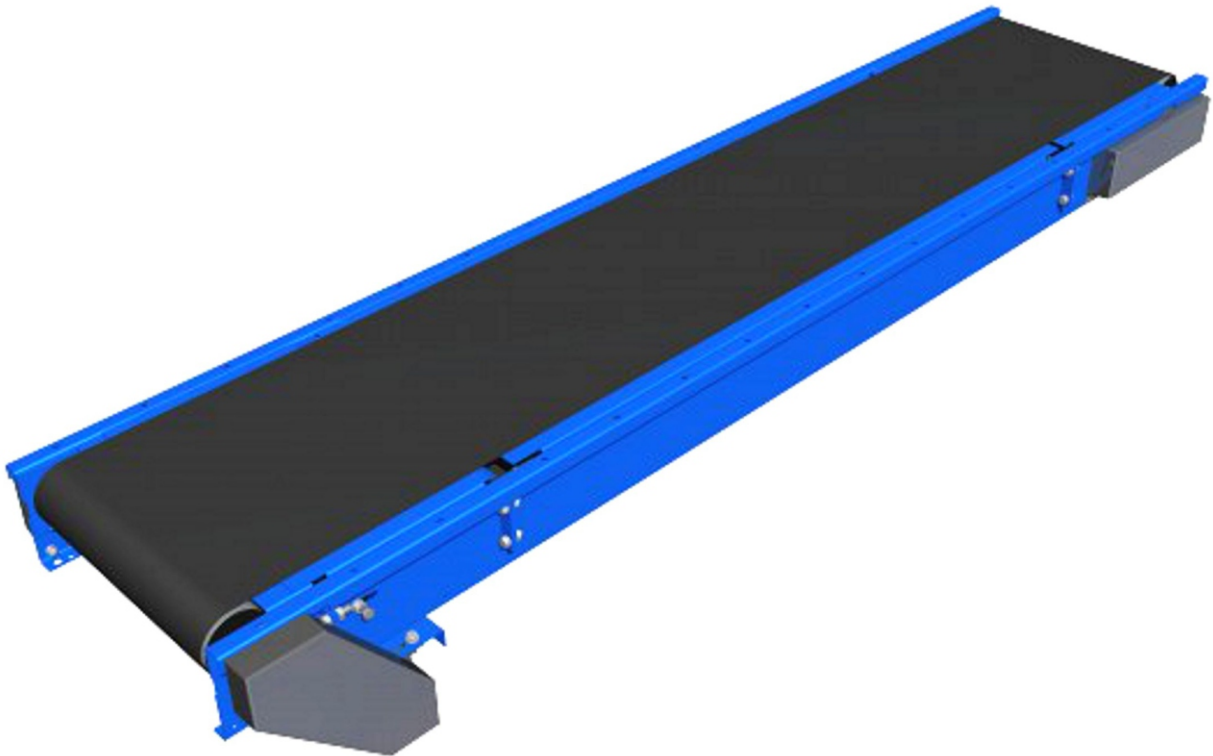

- Low initial cost.
- Reduced spare parts cost,
- Easy to install.
- Quiet operation.
- Smooth transportation.
- Fully reversible option (with intermediate drive).
- Greater versatility with the intermediate drive.
- Roller bed or Slider beds are available to reduce belt friction.
- Low maintenance cost.
- Low power requirement conserves energy.
- Available in: Powder coated as standard, aluminium or stainless steel.



# Heavy Duty Belt Conveyors

## Belt Conveyor - A Type

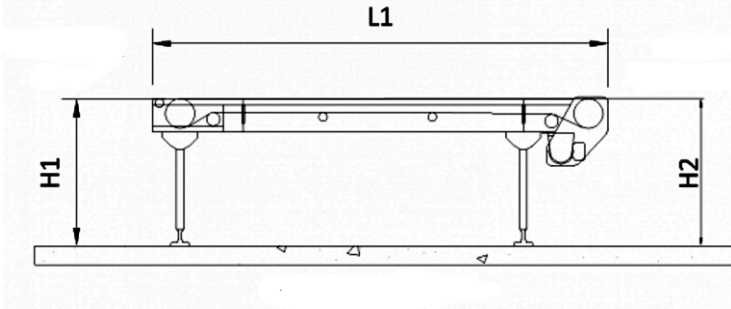

- End drive units fitted with SEW geared motor up to 0.55 kW.
- Variable speed option.
- Black PVC endless smooth top conveyor belt.
- Black grip top conveyor belt.
- Can be supplied with 60 / 150mm side guides.
- Optional pop out rollers at either or both ends.
- Full width steel undersheet fitted as standard.
- Available as Incline, Decline and Horizontal.

## Belt Conveyor - A1 Type

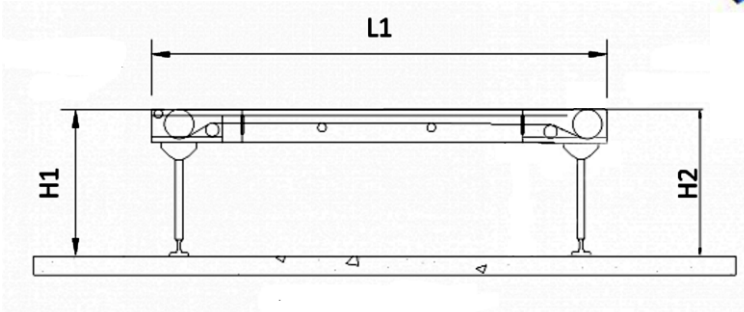

- Drum drive motor 0.18 kW up to 0.37 kW.
- Variable speed option.
- Black PVC endless smooth top conveyor belt.
- Black grip top conveyor belt.
- Can be supplied with 60 / 150mm side guides.
- Full width steel undersheet fitted as standard (local to drums only).



# Heavy Duty Belt Conveyors

## Belt Conveyor - B Type

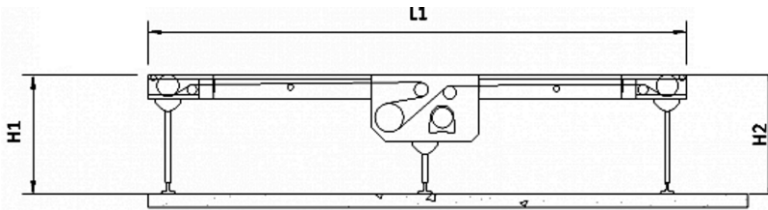
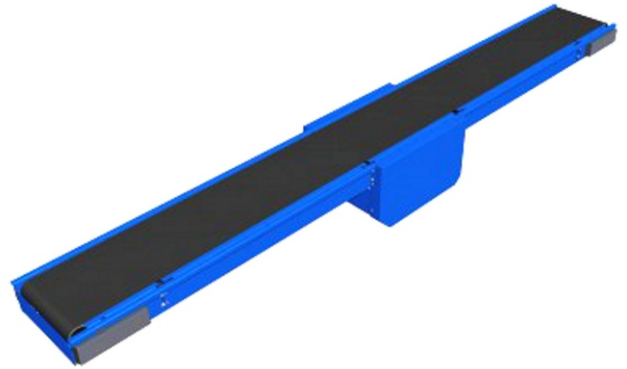

- Intermediate drive units fitted with SEW geared motor units up to 1.5 kW.
- Variable speed option.
- Reversible.
- Black PVC endless smooth top conveyor belt.
- Black grip top conveyor belt.
- Can be supplied with 60 / 150mm side guides.
- Optional pop out rollers at either or both ends.
- Full width steel undersheet fitted as standard.
- Available as Incline, Decline and Horizontal.

## Belt Conveyor - C Type

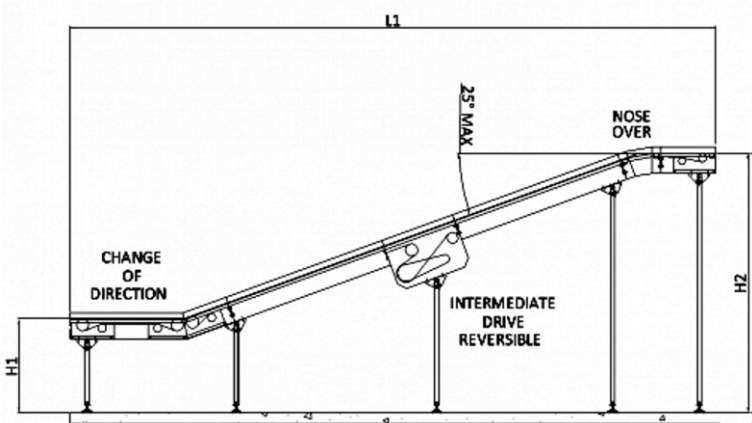

- Intermediate drive units fitted with SEW geared motor units up to 1.5 kW.
- Reversible.
- Variable speed option.
- Black grip top conveyor belt.
- Can be supplied with 60 / 150mm side guides.
- Optional pop out rollers at either or both ends.
- Full width steel undersheet fitted as standard.
- Standard angles of 10°, 15°, 20° and 25°. Other angles available upon request.
- Available as Incline, Decline and Horizontal.



# Heavy Duty Belt Conveyors

## Belt Conveyor - D Type

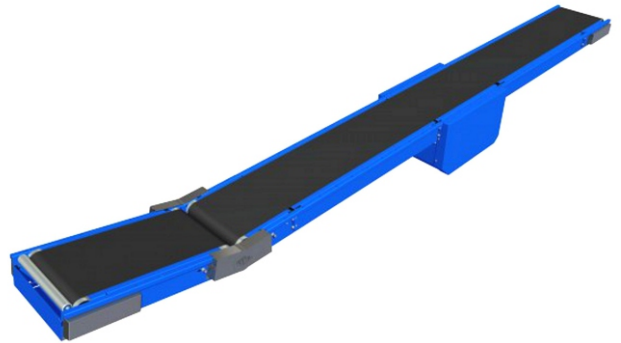
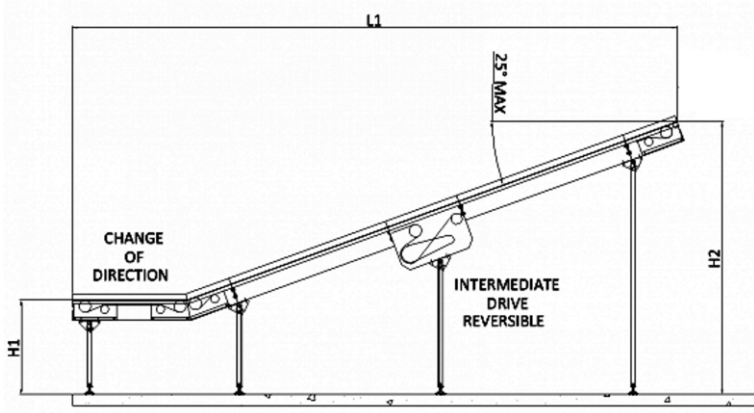

- Intermediate drive units fitted with SEW geared motors up to 1.5 kW.
- Variable speed option.
- Black grip top conveyor belt.
- Can be supplied with 60 / 150mm side guides.
- Optional pop out rollers at either or both ends.
- Full width steel undersheet fitted as standard.
- Standard angles of 10°, 15°, 20° and 25°. Other angles available upon request.
- Reversible.
- Available as Incline and Decline.

## Belt Conveyor - E Type

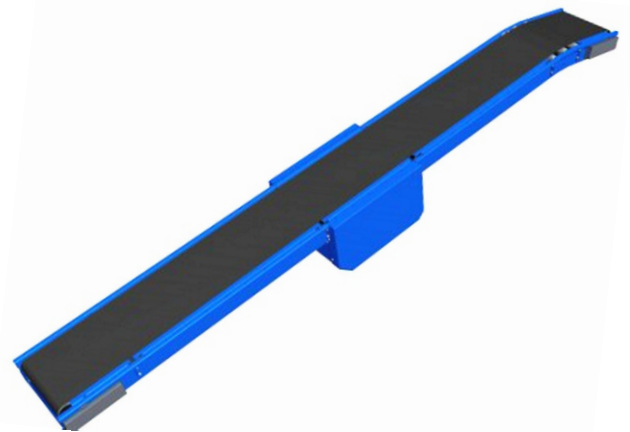
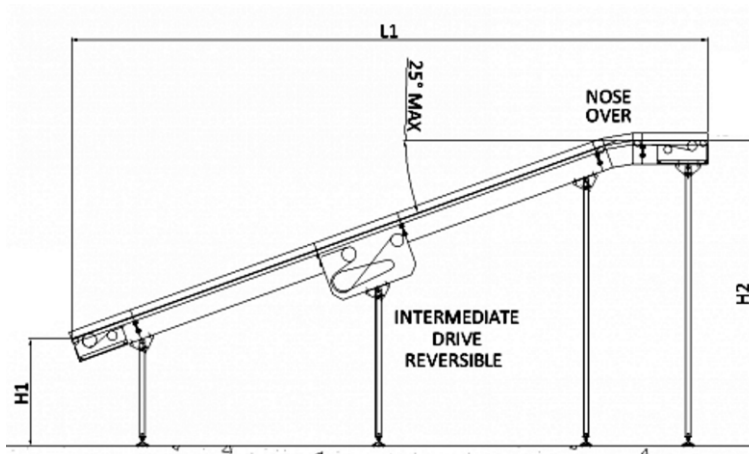

- Intermediate drive units fitted with SEW geared motor units up to 1.5 kW.
- Reversible.
- Variable speed option.
- Black grip top conveyor belt.
- Can be supplied with 60 / 150mm side guides.
- Optional pop out rollers at either or both ends.
- Full width steel undersheet fitted as standard.
- Standard angles of 10°, 15°, 20° and 25°.
- Other angles available upon request.
- Available as Incline and Decline..



# Heavy Duty Belt Conveyors

## Belt Conveyor - F Type

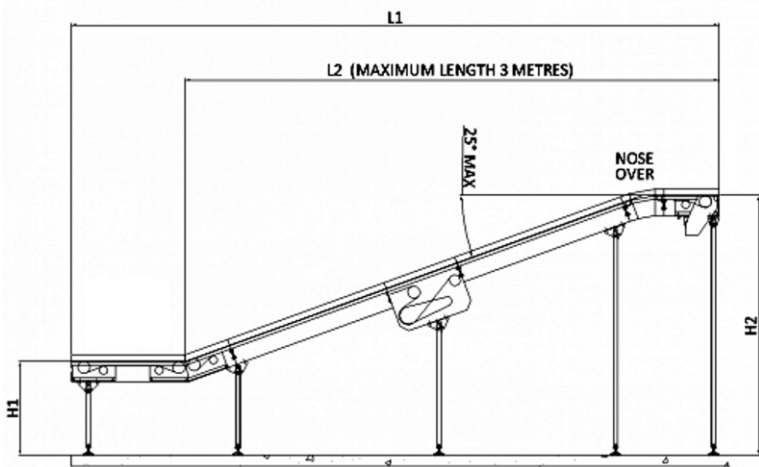

- End drive units fitted with SEW geared motor up to 0.55 kW.
- Variable speed option.
- Black grip top conveyor belt.
- Can be supplied with 60 / 150mm side guides.
- Optional pop out rollers at either or both ends.
- Full width steel undersheet fitted as standard.
- Standard angles of 10°, 15°, 20° and 25°. Other angles available upon request.
- Available as Incline and Decline.

## Belt Conveyor - G Type

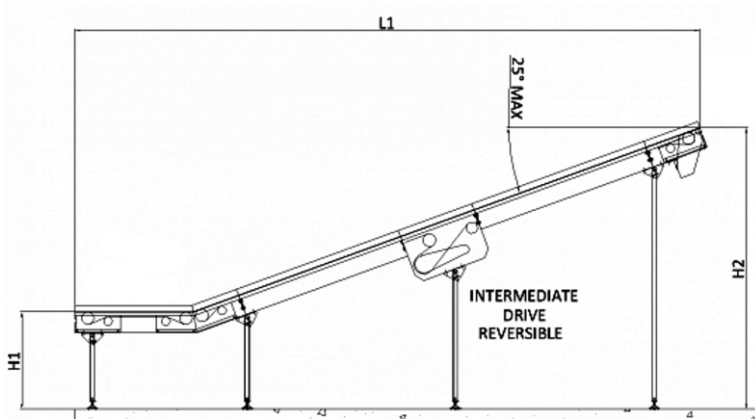

- End drive units fitted with SEW geared motor up to 0.55 kW.
- Variable speed option.
- Black grip top conveyor belt.
- Can be supplied with 60 / 150mm side guides.
- Optional pop out rollers at either or both ends.
- Full width steel undersheet fitted as standard.
- Standard angles of 10°, 15°, 20° and 25°.
- Other angles available upon request.
- Available as Incline and Decline..



# Heavy Duty Belt Conveyors

## Belt Conveyor - K Type

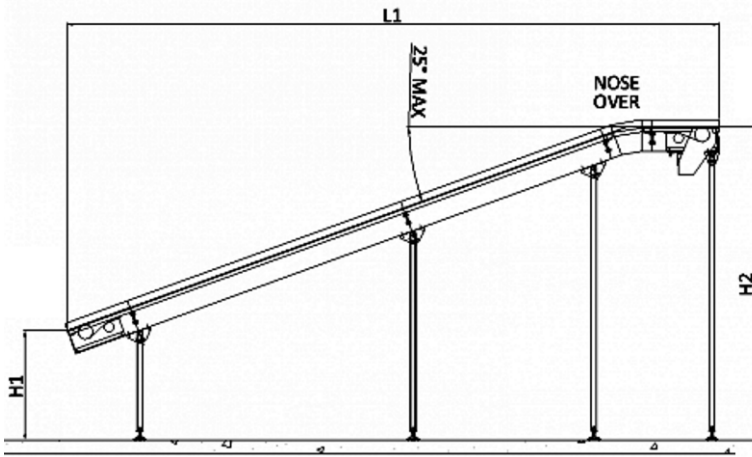

- End drive units fitted with SEW geared motor units up to 0.55 kW.
- Variable speed option.
- Black grip top conveyor belt.
- Can be supplied with 60 / 150mm side guides.
- Optional pop out rollers at either or both ends.
- Full width steel undersheet fitted as standard.
- Standard angles of 10°, 15°, 20° and 25°. Other angles available upon request.
- Available as Incline and Decline.

## Belt Conveyor - L Type

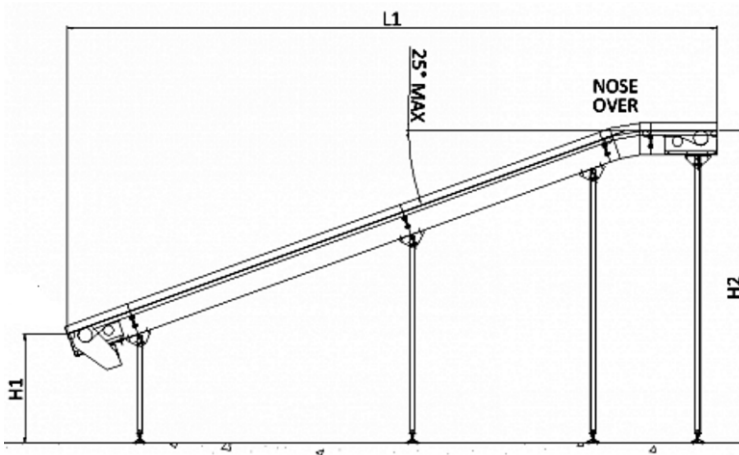

- End drive units fitted with SEW geared motor units up to 0.55 kW.
- Variable speed option.
- Black grip top conveyor belt.
- Can be supplied with 60 / 150mm side guides.
- Optional pop out rollers at either or both ends.
- Full width steel undersheet fitted as standard.
- Standard angles of 10°, 15°, 20° and 25°. Other angles available upon request.
- Available as decline only.



# Conveyors & Automated Handling Solutions



**FlexChain Conveyors**

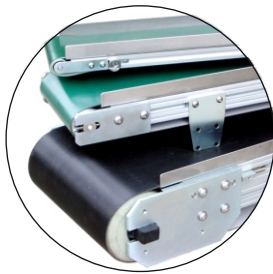

**Flat Belt Conveyors**



**Mat Top Bend**

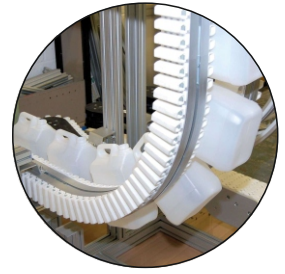

**Grip Conveyors**



**Heavy Duty Trough Conveyors**



**Plastic Container Handling System**

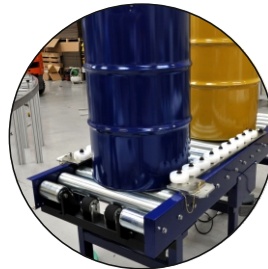

**Special Roller Conveyor**



**Rotating Storage Tables**



**Diverter Units**



**Indexing Buffer Stores**



**Elevators - Plastic or Stainless Steel**



**Luggage Handling**



**Multi-Lane Flat Belts**



**Ready Made Meal Conveyor Line**

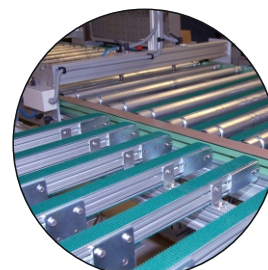

**Sheet Panel Transfer Unit**



**Fruit Packing Line**

## **MONK Conveyors Limited**

Unit 9, The Christy Estate, Ivy Road, Aldershot, Hampshire GU12 4TX  
Tel: +44(0)1252 369800 Fax: +44(0)1252 369801 Email: sales@monk-conveyors.co.uk  
Visit our website at: [www.monk-conveyors.com](http://www.monk-conveyors.com)

